

COMPLAINT

Small valve body section cannot be reamed consistently

CAUSE

Due to the complex shape and small size of the TF-80SC and TF-60SN valve bodies, aligning and securing the valve bodies for reaming the Lockup Control and Solenoid Modulator valve bores are extremely difficult.

CORRECTION

The Sonnax adapter plate and valve body reaming fixture, used together, make consistent reaming results possible. After bolting the valve body to the plate, the plate is then clamped to the VB-FIX, holding the valve body securely aligned, without distorting the bore.

Adapter Plate for VB-FIX

F-15741-TL29PL

1 Adapter Plate	
1 Screw	M5-0.8 x 12mm
1 Screw	M5-0.8 x 15mm
1 Screw	M5-0.8 x 25mm

Required to install 15741-18K & 15741-29K in: Volvo (AM6); Opel (AF40); Peugeot (TF80); Saab (AF40/6); Land Rover (TF80); BMW (6F21WA) & VW/Audi (09G, 09K, 09M).

The above Adapter Plate is used with these products below:

Solenoid Modulator Valve Kit
15741-18K Tool Kit Required

Tool Kit for above kit
F-15741-TL18 VB-FIX Required

Lockup Clutch Control Valve Kit
15741-29K Tool Kit Required

Tool Kit for above kit
F-15741-TL29 VB-FIX Required

Reaming Fixture
VB-FIX

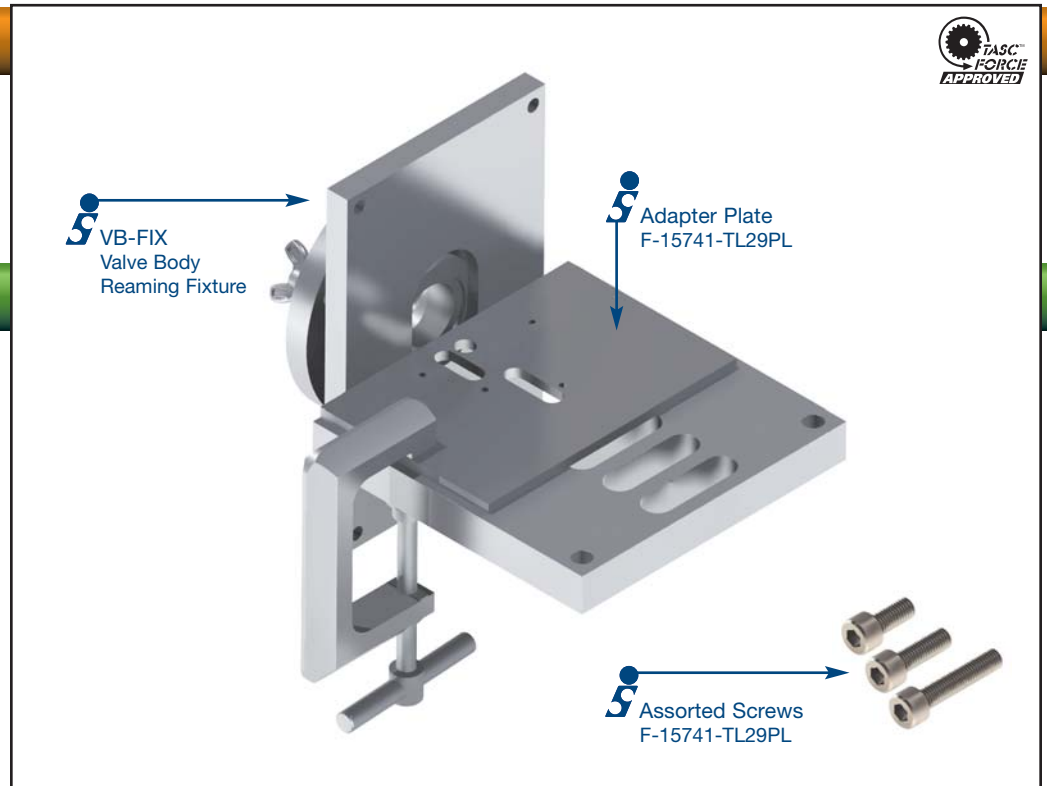

Summary

In the TF-80SC & TF-60SN applications there is no way to align and secure the valve body to ream the Lockup Control or Solenoid Modulator valve bores. The combination of the adapter plate, F-15741-TL29PL & VB-FIX reaming fixture and the specially designed tool kit, F-15741-TL18 or F-15741-TL29, allows these valve bodies to be repaired. The fixture provides an external rigid pilot bore for the reamer and guide pin. The plate allows the valve body to be secured without distorting the bore.

Features & Benefits

- Salvage expensive and hard to find valve body cores.
- Patent-pending unique self-aligning device produces consistent, reliable results and reduces reaming failure.
- Holds valve body securely, without distorting the bore.