

COMPLAINT

SECONDARY COMPLAINT

Transmission slips

- Leakage of 4th gear and TCC oil pressure

CAUSE

The U-shaped bracket at the top of valve body that retains the boost valve and spring breaks, allowing the spring and valve to fall out of position.

CORRECTION

The Sonnax replacement bracket resists cracking or breaking.

Boost Valve Spring Retainer

22990-01

5 Retainers

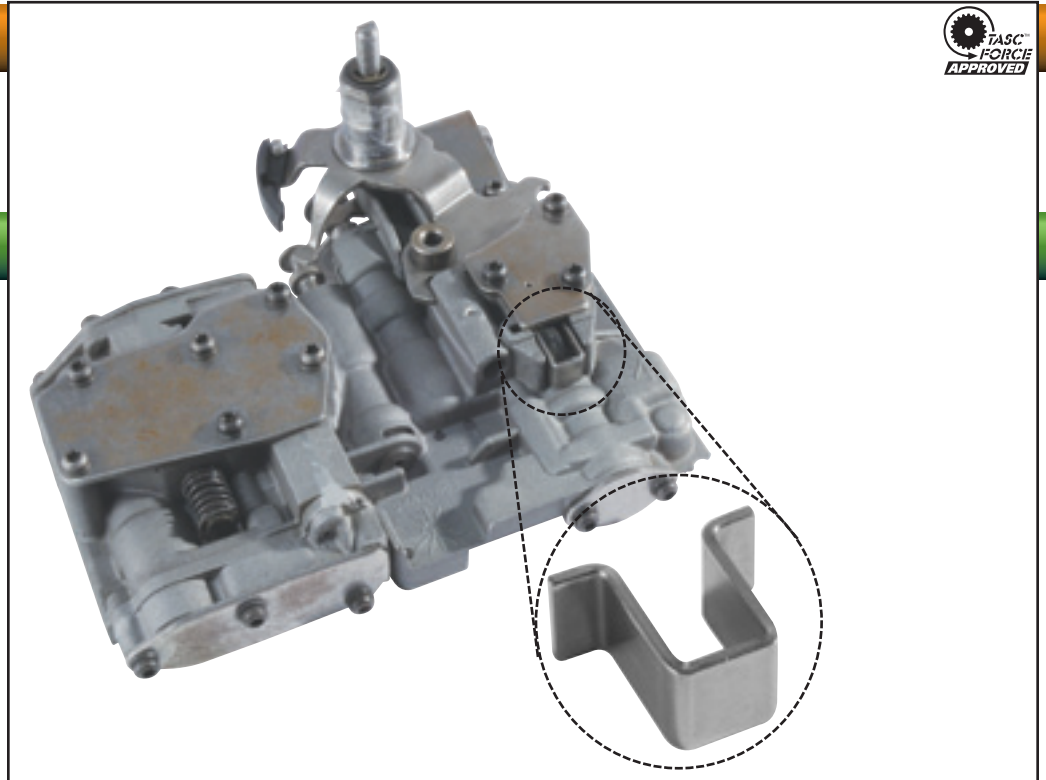

Sonnax Part Summary

The OEM retainer in 42-46-47RH/RE applications is prone to cracking and breaking, which allows the boost valve and spring to fall out of position. That causes a leak of 4th gear and TCC oil pressure. The Sonnax replacement retainer eliminates this leakage by securely keeping the valve and spring in place.

Features & Benefits

- Sonnax retainer is made from heavier, more wear-resistant material for longer life.

Save

\$200 in valve body replacement costs