

COMPLAINT

SECONDARY COMPLAINTS

Input drum wear at the center support

- Excessive wear of center support and case lugs at contact points

CAUSE

Slight motion of center support as intermediate clutch piston applies and releases.

CORRECTION

The Sonnax support ring increases the contact area between the center support and the case and helps keep the center support in alignment, greatly reducing center support wear.

Support Ring

36743-02
1 Support Ring

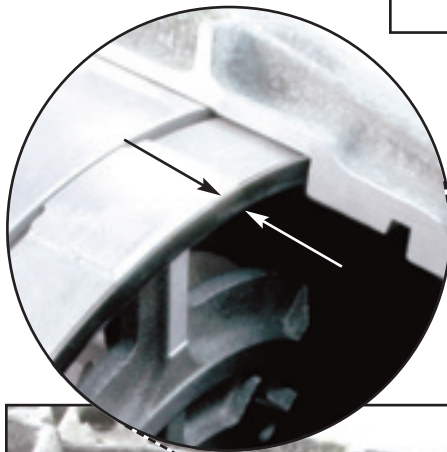
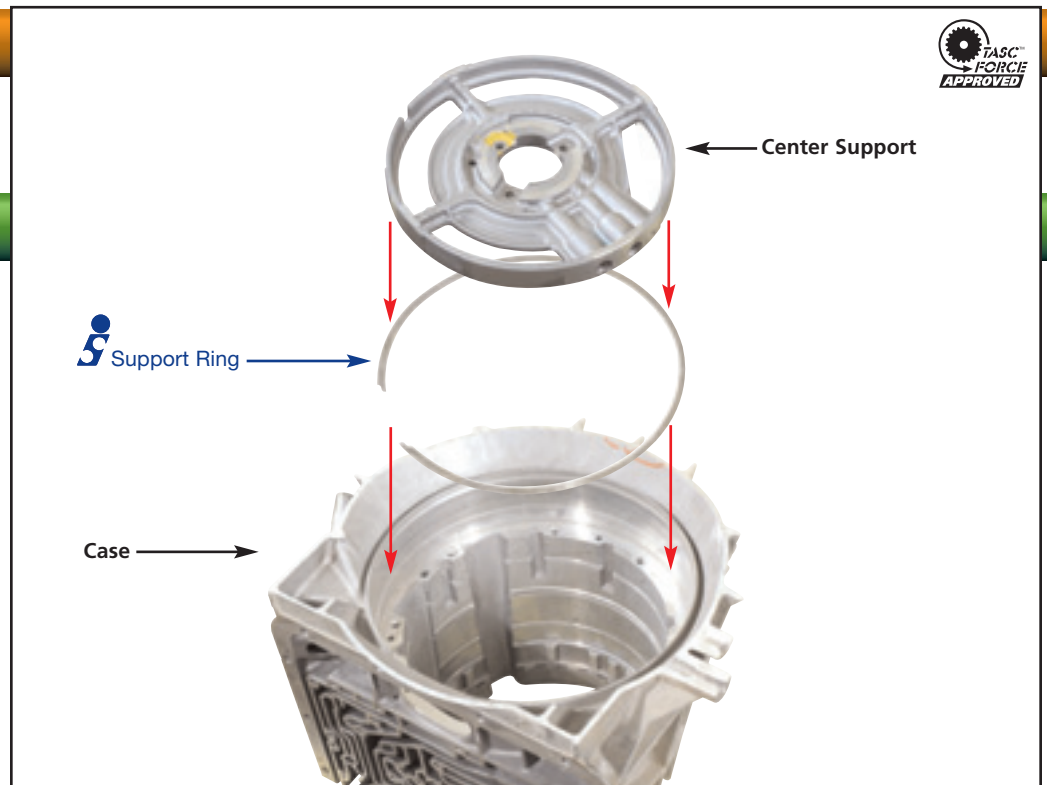

Sonnax Part Summary

Movement between the center support and case causes wear on the rear of the center support where it contacts the case lugs and requires center support replacement. The steel Sonnax support ring installs between the case lugs and center support, giving more contact area with the center support and eliminating future wear. Since the .048"-.051" thickness of the steel ring needs to be machined off of the rear of the center support, this allows worn supports to be salvaged and reused.

Features & Benefits

- Increased contact area at both center support and case reduces wear
- Salvages worn center support
- Keeps center support in alignment
- Minimizes drum wear at the support

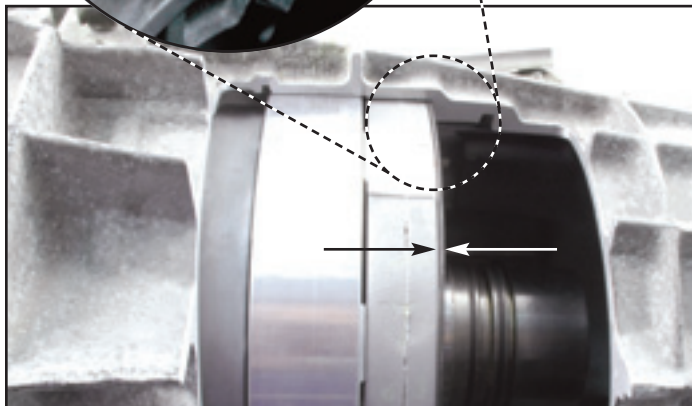

< Window has been cut out of the E4OD case to show where support ring 36743-02 lives when assembled (noted between arrows).