

COMPLAINT

SECONDARY COMPLAINTS

Flare upshifts or downshifts

- Bind up, excess clutch overlap, clutch distress • Pressure control out of range codes

CAUSE

The C2 clutch control valve provides source pressure for control of clutch (band) apply and release. Responding to TCU and the linear solenoid, the C2 control valve will establish control timing of apply and release relative to engine torque. Bore wear will cause an overlap or premature exhaust of clutch pressure.

CORRECTION

Ream the valve bore and install the Sonnax improved valve and sleeve assembly and calibrated spring.

C2 Clutch Control Valve Kit

39741-05K

- 1 C2 Clutch Control Valve
- 1 C2 Clutch Control Sleeve
- 1 Spring



F-39741-TL5

- 1 Reamer Jig
- 1 Guide Pin, C2
- 1 Guide Pin, C3
- 1 Reamer



Note: Fits Volvo (AM6); Opel (AF40); Peugeot (TF80); Saab (AF40/6); Land Rover (TF80); Ford (AF21) & Mazda (AW6A-EL).

Note: Tool kit **F-39741-TL5** also can be used to install **39741-08K**, C3 Clutch Control Valve Kit.

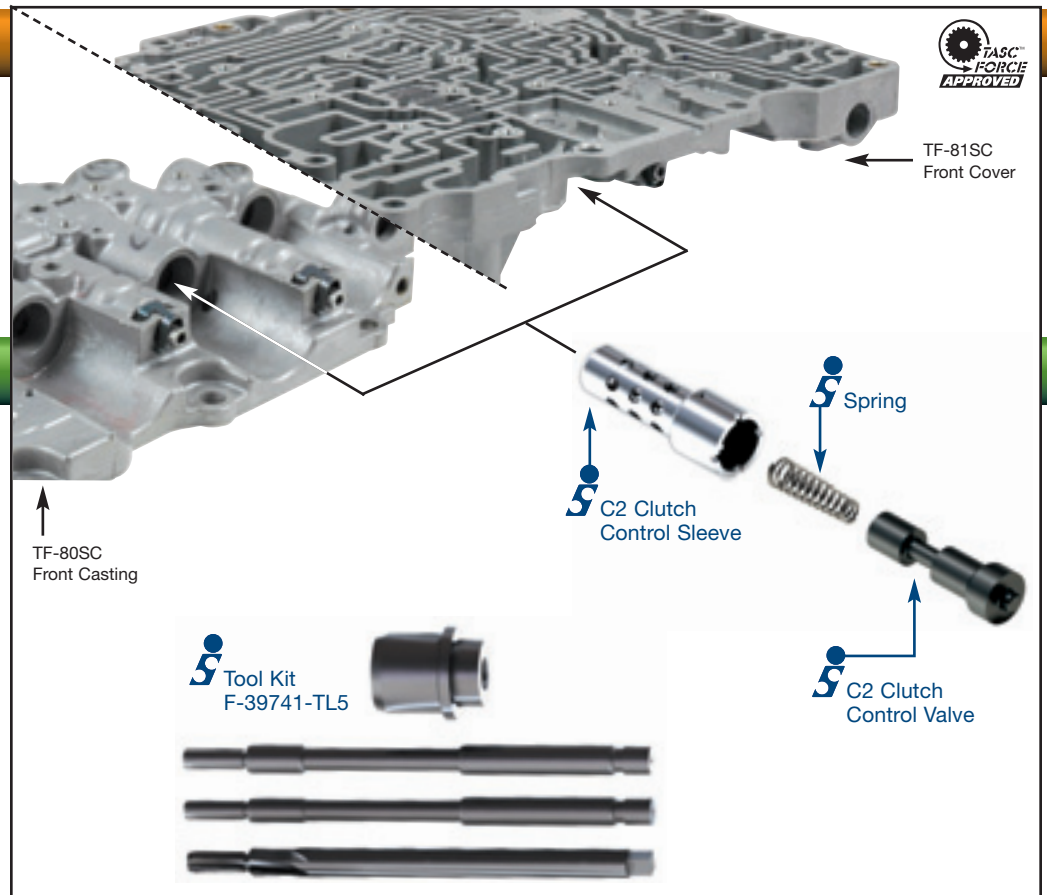

Features & Benefits

- Highly wear-resistant sleeve provides additional support to the control valve.
- Hard-coat anodized aluminum valve is wear-resistant and has more sealing contact with bore than OEM to minimize leakage.
- New spring maintains OEM operating pressures.
- Allows salvage of previously non-repairable valve bodies and avoids searching for and/or purchase of expensive replacement valve bodies.

You need this if...

Either a Wet Air Test or a Vacuum Test in the locations shown, result in leakage. A vacuum test must hold a minimum of 18".

