

COMPLAINT

SECONDARY COMPLAINTS

Converter apply/release complaints

- Harsh lock-up • Burned converters • Lube related failures

CAUSE

Severe wear of the valve and bore allowing EPC and/or balance pressure loss.

CORRECTION

The Sonnax secondary pressure regulator valve repair kit with upgraded materials and minimal clearances prevent wear and restore proper hydraulic function.

Oversized Secondary Pressure Regulator Valve Kit

57917E-16K

- 1 Oversized Secondary PR Valve
- 1 Matched Spring
- 1 Oversized End Plug



Note: Fits applications U140E/F, U151E/F, U240/241E & U250E

F-57917E-TL16

- 1 Reamer Jig
- 1 Guide Pin
- 1 Reamer

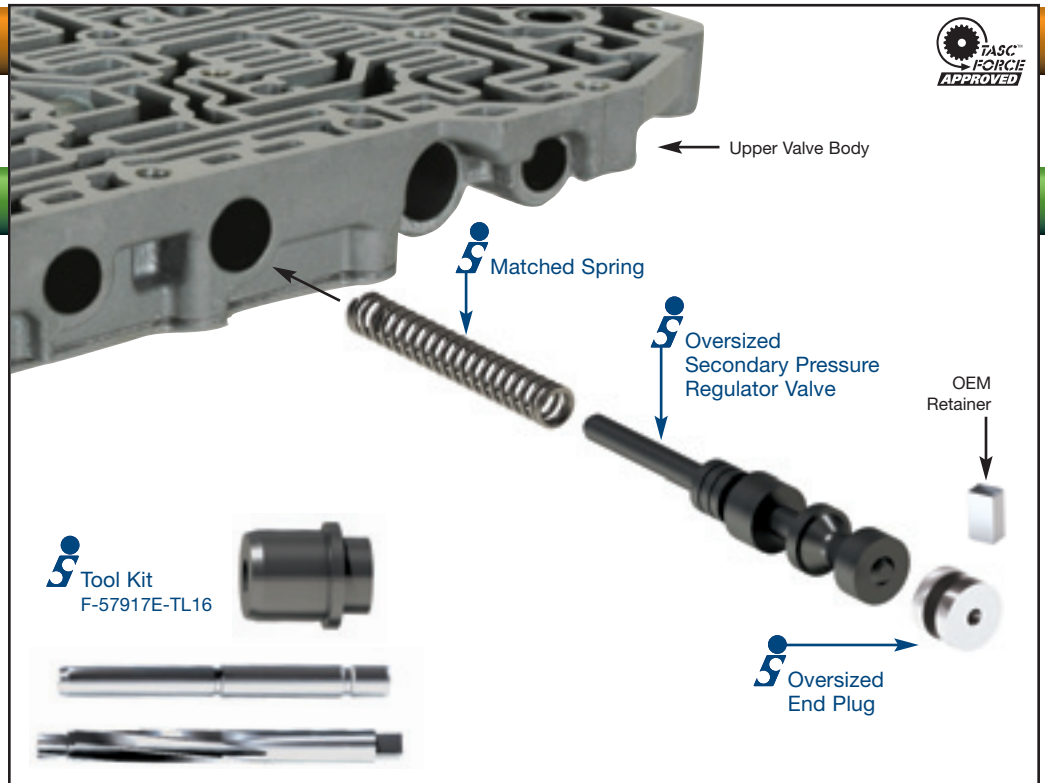

Sonnax Part Summary

The continuous oscillation of the secondary regulator valve wears the valve spools and valve body bore at the contacting surfaces. Such wear results in TCC pressure irregularities and valve instability. If pressure is high, harsh lock-up clutch engagement can result. If the pressure is too low, the TC clutch cannot achieve complete lock-up. Continuous clutch slippage will lead to burned clutch material and converter. Under these conditions loss of mileage and poor drive-ability are to be expected.

Features & Benefits

- Oversized hard-coat anodized valve is manufactured to highly precise tolerance to resist wear.
- The oversized valve and included matched spring restore OEM regulated pressure specifications.
- Kit allows salvage of previously non-repairable valve bodies and avoids searching for, and purchase of, expensive replacement valve bodies.