

Aisin AW TF-81SC*

*Also fits Ford (AF21) & Mazda (AW6A-EL).

sonnax®

TIME TESTED • INDUSTRY TRUSTED®

1 Automatic Drive • P.O. Box 440 • Bellows Falls, VT 05101-0440 USA
(800) 843-2600 • (802) 463-9722 • F: (802) 463-4059 • www.sonnax.com

1 15741-29K Lockup Clutch Control Valve Kit



Helps cure:

- RPM surge on coast/light acceleration
- Harsh downshifts

Note: Requires tool kit F-15741-TL29 & the VB-FIX reaming fixture.

2 15741-53K Lockup Clutch Control Plunger Valve Kit

Helps cure:

- TCC apply & release concerns/TCC codes
- RPM surge on coast/light acceleration

3 39741-01K Oversized Main Pressure Regulator & Boost Valve Kit



Helps cure:

- High line pressure in Reverse
- Overheated fluid & TCC lining

Note: Requires tool kit F-39741-TL & the VB-FIX reaming fixture.

4 39741-11K Secondary Pressure Regulator Valve Kit



Helps cure:

- High/Low SLT pressure
- Overheated fluid, bushings & converter

Note: Requires tool kit F-39741-TL11 & the VB-FIX reaming fixture.

5 39741-18K Solenoid Modulator Valve Kit



Helps cure:

- Code 734, 735, 729
- Kickdown slip/shock
- 4th/5th/6th Slip

Note: Requires tool kit F-39741-TL18 & the VB-FIX reaming fixture.

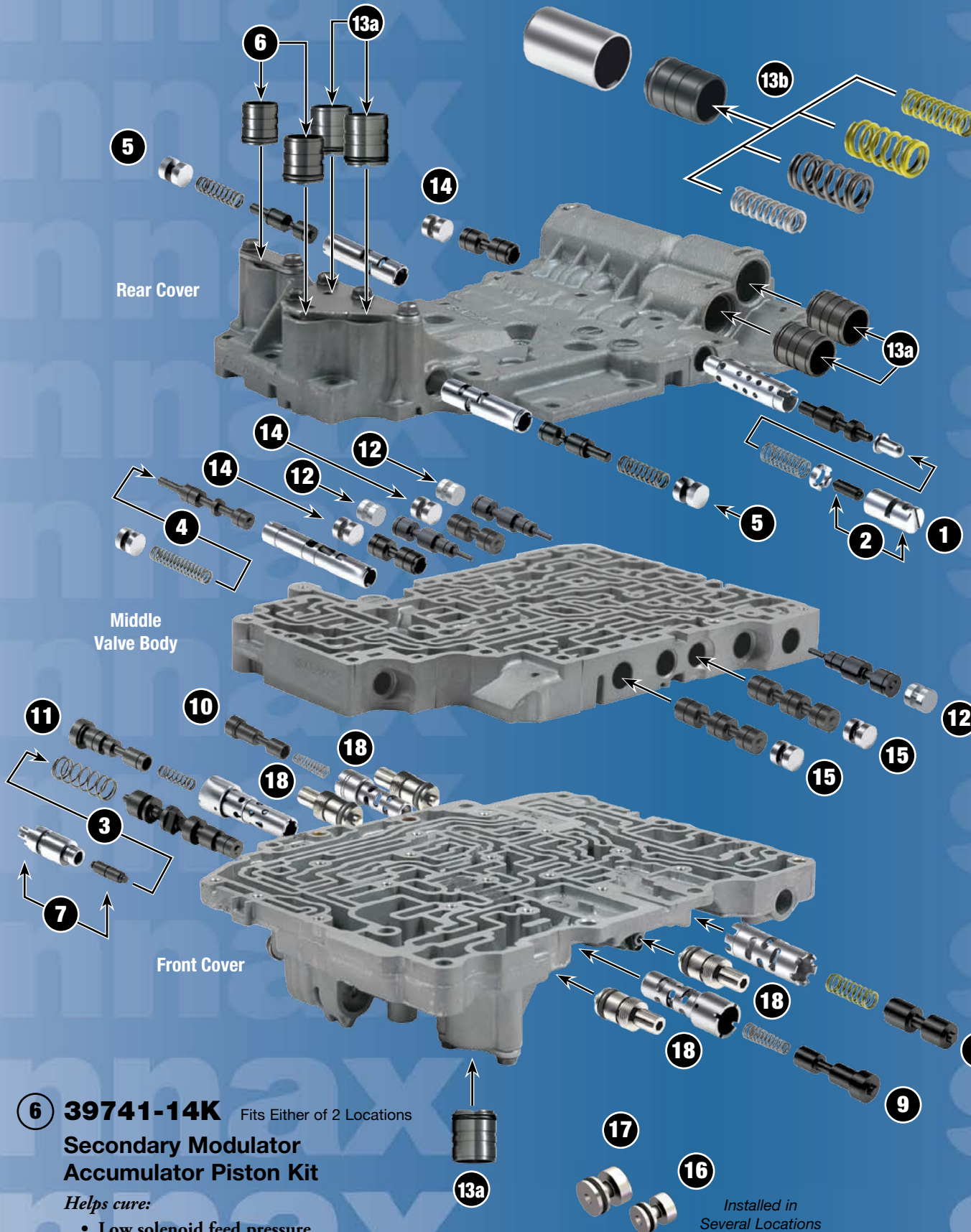

6 39741-14K Fits Either of 2 Locations Secondary Modulator Accumulator Piston Kit

Helps cure:

- Low solenoid feed pressure
- Shift concerns/codes

Note: This kit does not fit TF-80SC units.

7 39741-44K Boost Valve Kit

Helps cure:

- Delayed Reverse
- Low line pressure in Reverse
- B2 Brake/C3 clutches burned

8 15741-25K Valve/Sleeve/Spring 15741-55K Oversized Valve/Spring C1/K1 Clutch Control Valve Kit



Helps cure:

- Flare shifts
- Downshift bind-ups
- Pressure control out-of-range codes

Note: 15741-25K requires tool kit F-15741-TL25; 15741-55K requires tool kit F-15741-TL55 and both require the VB-FIX reaming fixture.

9 39741-05K Valve/Sleeve/Spring 39741-46K Oversized Valve/Spring C2 Clutch Control Valve Kit



Helps cure:

- Flare shifts
- Downshift bind-ups
- Pressure control out-of-range codes

Note: 39741-05K requires tool kit F-39741-TL5; 39741-46K requires tool kit F-39741-TL46 and both require the VB-FIX reaming fixture.

10 39741-08K Valve/Sleeve/Spring 39741-50K Oversized Valve/Spring C3 Clutch Control Valve Kit



Helps cure:

- Flare shifts
- Downshift bind-ups
- Pressure control out-of-range codes

Note: 39741-08K requires tool kit F-39741-TL5; 39741-50K requires tool kit F-39741-TL50 and both require the VB-FIX reaming fixture.

11 39741-22K Valve/Sleeve/Spring 39741-48K Oversized Valve/Spring B1 Band Control Valve Kit



Helps cure:

- Harsh downshifts
- 1-2/2-3/5-6 Flares

Note: 39741-22K requires tool kit F-39741-TL22; 39741-48K requires tool kit F-39741-TL48 and both require VB-FIX reaming fixture.

12 15741-63K Fits Any of 3 Locations Oversized Clutch Cutoff Valve Kit



Helps cure:

- Burnt clutches
- Overheated fluid
- Hard/Soft shifts
- Erratic shift timing

Note: Requires tool kit F-15741-TL63 & the VB-FIX reaming fixture.

13a 15741-14K Fits Any of 5 Locations Accumulator Piston Kit

Helps cure:

- Delayed engagement
- Forward slip
- Burnt clutches/bands

13b 39741-42K Fits Any of 5 Locations Accumulator Piston Kit

Helps cure:

- Severe wear at accumulator bores
- Low clutch oil pressure
- Low TCC/EPC pressure

14 15741-49K Fits Any of 3 Locations Oversized Two-Spool Relay/Signal Valve Kit



15 15741-50K Fits Either of 2 Locations Oversized Three-Spool Relay/Control Switch Valve Kit

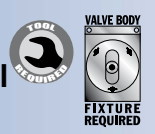

Helps cure:

- Gear ratio & solenoid codes
- No shifts/various shift concerns

Note: Both kits require tool kit F-33741B-TL1 and the VB-FIX reaming fixture.

16 15741-35K 5 small, 9mm 17 15741-36K 5 large, 11mm O-Ringed End Plug Kit

Helps cure:

- Shift concerns associated with circuit pressure loss

Note: These kits fit multiple locations.

18 15741-48K Fits Any of 4 Locations Spring Adjuster Kit

Helps cure:

- Soft/Long/Flare shifts
- Intermediate clutch/solenoid codes